

Operating instruction

Recrprocator

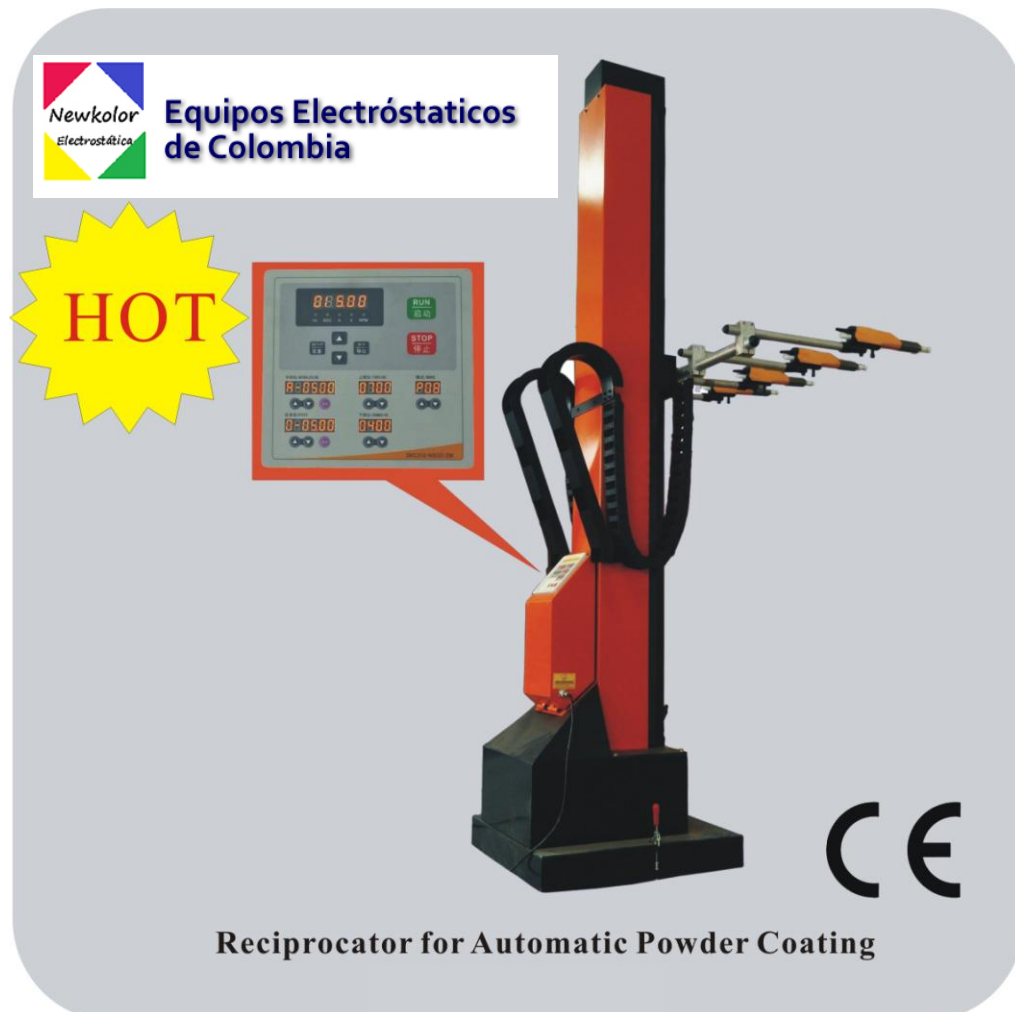

Technical safety regulations for stationary electrostatic powder spraying equipment

1. The powder spraying equipment should only started up and used once the operating instructions have been carefully studied , improper use of the controlling device can lead to accidents ,malfunction or damage to the control itself
2. Before every start-up check the equipment for operational safety(regular serving is essential)!
3. The plug must be disconnected before the machine is opened for repair
4. The plug and socket connection between the powder spraying equipment and the mains network should only be taken out when the power is switched off
5. Caution must be exercised when working with a powder/air mixture! A powder/air mixture in the right concentration is flammable! Smoking is forbidden in the entire plant area!
6. As a general rule for all powder spraying installations ,persons with pacemakers should never enter high voltage areas or areas with electromanagnetic fields ,persons with pacemakers should not enter areas with powder spraying installations

Technical Data General information

Maximum available programs	9
Max stoke height	2m
Maximum speed	0.8m/s
Minimum speed	0.08m/s
acceleration	0.1m/s ²

Electrical data

Nominal input voltage	170-264VAC single phase
Tolerance	+10%/-10%
frequency	50/60hz
Fuse	10.0AT
Power consumption	2.5kw

Dimensions

width	0.7M
Depth	0.7M
Height	2980mM
weight	200kgs

Installation Instructions

1) Wire connecting guiding:

1. Make sure it is grounded well before using ,the resistor < 100 Ohm.
2. Reciprocator must controlled by the single phase power ,and it can be cut off at any time.

2)Machinery install:

Temperature: $-10^{\circ}\text{C} \sim +50^{\circ}\text{C}$

Altitude: < 1500m

Attack :avoid attack on the control unit

Shaking :do not put the control unit on the shaking place.

electromagnetic interference :do not put the control unit on the place that is around the electromagnetic source.

Air pollution: do not put the control unit on the place that is full with dust or corrosive air ,prevent the dust come into the control unit.

Moisture: do not put the control unit on the moisture place.

Level: the track on the ground need on the standard level ,tight it with expansion bolt.

Performance:

Dynamic parts are made from top brand worm reduction gear ,with the precision type sensor , the machine can be moving stably under the high speed.

Speed adjust department use the hongkong TTK brand inverter, this inverter is reliable and flexible with the microprocessor control and IGBT technology .The inverter and electric machinery are protected well by the perfect protect system.

Control units use the new digital controller ,the user can set the spraying data very easily on the digital display .The controller can be reset coating process ,problem checking ,data set, remote control and so on more than 9 processes.

Mechanical parts use 8 wheels , the wheels embrace the metal tube tightly from the 4 direction and move by the function of the chains. The chains are make of special material, moving stable, little noise, lower wear and so on .

Gun rod and gripper are made of aluminum, it is light, moving stably and beautiful.

The reciprocator moving speed is 0.08m/second ~0.8m/second can be adjusted .The stroke is 1.5m,2.1m,2.8m,it also can be ordered according to the customers request.

Attention:

Always pay attention to the gun positions the maximum height of the gun slots in the booth ,if an incorrect (too high) stroke limit is set , this can lead to the damage of the reciprocator or the booth

Configuration

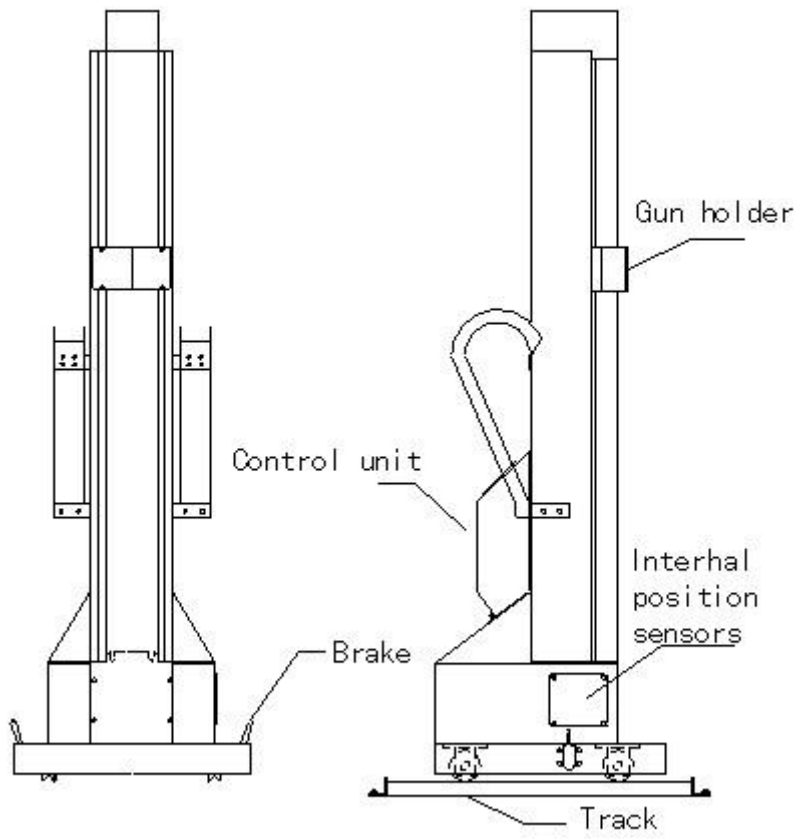

Control panel

1) Assembly dimensions

Panel dimensions: 190mmx180mm

Connecting cable :1.5m

Cutout dimensions: 171mmx168mm

2) Technical data

supply voltage :5v ,

operation temperature :0-50 degree

Supply current: 500 mA

storage temperature: -10-50 degree

Life of keyboard : > 1 million times

operation humidity: 20-90% RH

3) Assembly

(1) mounting of control panel

Control panel is mounted on the operation table with 4 clamping levers

(2) connecting control panel

On the side of control panel the cable is connected with the 9-pin D-Sub plug , on the other side of TTK inverter , 7 of 9 cables are connected to the correct terminals on TTK inverter, shown as the following picture . the other 2 cables are connected to the external power supply

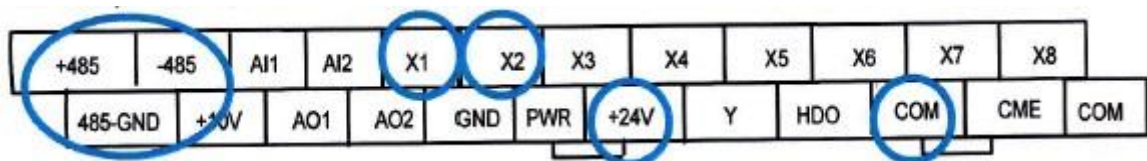

Pin assignment of the connecting cable

Green -V+ ,Black -V- (External power supply) Red - 485+, Brown-485 ,Blue -485 GND ,Gray -24V ,

Yellow -COM Orange -X1, Purple -X2

Pin assignment on the sensor terminals :

Suggested sensor model: WDS35D

The 2 connecting cables are connected to the pin1 ,pin 2, pin 3, if the value of the sensor increases when

the machine is going down, then exchange the cables on pin1 and pin 3, details about the connecting sensor ,please ask for the supplier

Function description

(1) Key function

>>: shifts the parameters ,such as the inverter frequency,the value of position sensor, the current,the voltage and motor speed

Setup: 

This is regarding to the password ,we do not suggest to use

Increments and decrements the inverter frequency

Run:

Starts the machine



Stop:

Stops the machine and recovers from the trouble status to the normal status after clearing up the faults

Operation instruction

Nine operation modes are designed for the control panel

The first five operation modes P00 to P05 are named single speed operation modes,that means the machine is going up and down with one constant speed.The speed can be regulated with the key

 " under the LED displayer named - speed ,in this mode the key  is invalid.

The topside and downside positions are regulated with the key  und the LED displayer named - topside and- downside

The next two modes P06 to P07 are named double speed operation modes, that means the machine is going up and down with 2 constant speeds. For example the LED displayer name-speed is displayed 0-10.00 ,which defines the speed 10.00Hz of the first stroke. The LED displayer named –middle side is displayed –A-0500 which defines the speed switch Point

between the first and second stroke. Details are demonstrated in the following diagram. The last mode P08 is named triple speed operation model, that means the machine is going up and down within 3 constant speeds. The operation is the same with double speed operation modes

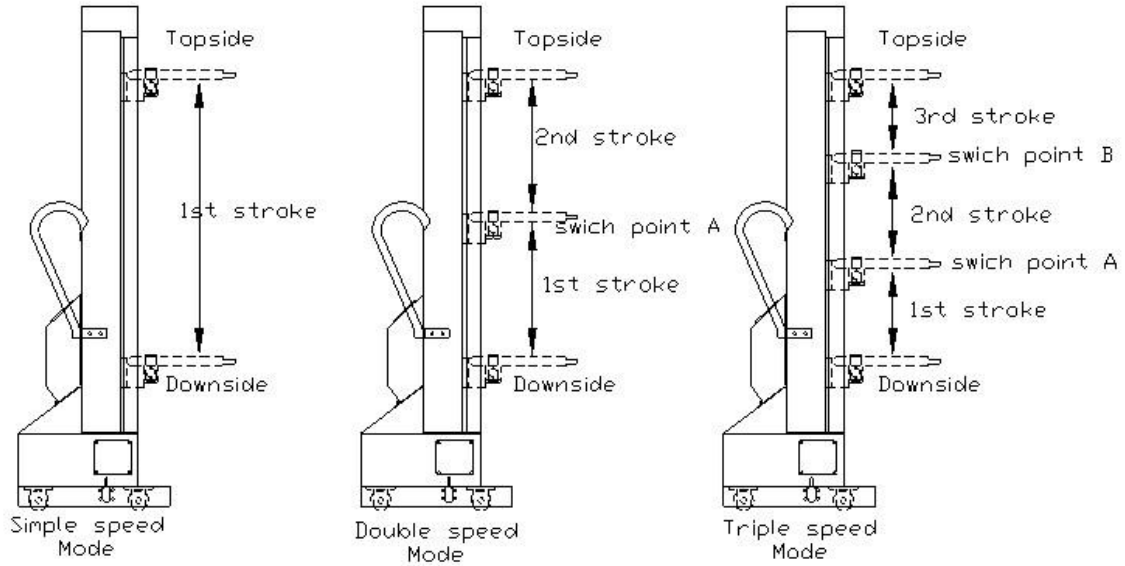

Parameter settings for TTK1000 inverter

- Sets F0-00=8 s elects the 485 modbus source as the frequency input
- Sets F0-05=1 Defines the start-up and control with I/O terminals
- Sets F0-12=0.4 Defines the acceleration time as 0.4 seconds
- Sets F0-13=0.4 Defines the deceleration time as 0.4 seconds
- Sets F2-13=1 Allows the I/O terminals recovery after restarting the inverter
- Sets F4-02=1 Defines x2 terminals as reverse rotation

Other useful parameters while testing the machine:

- Parameter F0-06 Defines the direction of motor rotation
- Parameter: Fd-01 Defines the protection for parameter settings

Maintenance

1. The chains need be checked and adding machine oil on time .Need tight the chain if the chain is too long1,chain need changed each year ,the chain type is 10A. Please note ,when you change the chain please make sure the chain mechanical position is not change.
2. Clean the wheel and metal tube on time ,if there are too much dust ,please clean it use the knife .Make the working condition clean it the best way.
3. Check if the controller is sealed ,if the seal is broken and please change the new one .Clean all the accessories in the controller with air ,after cleaning and please close it on time .Or the dust will come into the controller.
4. Clean and check the base on time ,clean the motor with air.
5. If the mechanical situation is changed ,please readjust the stand point ,or the moving will out of control .The method is :push the key ↑ or ↓,let the spray gun move to the middle of the working stroke ,then adjust the sensor on the bottom of the base ,when the data on the “m” indicated 500 and then the setting is finished.

Warning:

- Before start the reciprocator ,please make sure the locator rob is already put in the base locator hole .Or if it is out of control ,the machine maybe turned off ,this point is very important.
- Do not closed to the moving gun rod ,if need repairing ,please turn off the power at first to avoiding the harm to the people.
- Do not add oil on the gun rod moving wheel and the square track ,because too much powder will stick on the oil and the track will stuck by the powder.
- Press the key lightly with finger ,no need excessive force. Do not use sharp objects ,or the key will be damaged.
- High speed ,shot stroke will shorten the reciprocator's life.
- If above actions caused the big accidents ,the reciprocator manufacture is irresponsible.